

## Residential & Commercial Energy Storage WIS 5.0L B1 Battery System



044.SKSQ14100

Version: 1.0

## **About this Document**

This document describes the installation, electrical connection, operation, commission, maintenance and troubleshooting of WIS 5.0L-B1 Battery System (hereafter simply put WIS 5.0L). Before installing and operating WIS 5.0L-B1, ensure that you are familiar with product features, functions, and safety precautions provided in this document.

## Table of Contents

<b>1.Product Overview</b>	<b>1</b>
1.1 Product Description	1
1.2 Appearance	1
1.2.1 Dimension (unit:mm)	1
1.2.2 Introduction to the battery operation panel	2
1.3 Function and Introduction	3
1.4 Battery software upgrade	4
1.4.1 Upgrade via USB	4
1.4.2 Upgrade via Inverter	4
<b>2 Safety</b>	<b>5</b>
2.1 Application	5
2.2 Safety Precautions	5
2.2.1 Environment requirements	5
2.2.2 Operation and Precautions	6
2.3 Warning labels	6
2.4 Emergency Responses	7
<b>3 Storage and Transportation</b>	<b>8</b>
3.1 Storage Requirements	8
3.2 Transportation Requirement	8
<b>4 Installation</b>	<b>9</b>
4.1 Installation Environment	9
4.2 Installation Required Tools	9
4.3 Check	10
4.3.1 Pre-installation Check	10
4.3.2 Check Packing List	10
4.4 Installation	11
4.4.1 Battery Placement	11
4.4.2 Communication Cable Communication	12
4.4.3 Single Battery Installation	12
4.4.4 Battery Capacity Expansion Installation	14
4.4.5 Battery Pack Power Expansion Installation	15
4.4.6 Battery Pack Capacity and Power Expansion Installation	16
4.4.7 Stackable Installation with Bracket Support	17
<b>5 Power on/off</b>	<b>18</b>
5.1 Power on	18
5.2 Power off	18
<b>6 Maintenance Guide</b>	<b>19</b>
6.1 Preparation	19
6.2 Battery Replacement	19
6.3 System Failure Information List and Trouble Shooting Suggestions	19
<b>7 Technical Specifications</b>	<b>21</b>

## 1.Product Overview

### 1.1 Product Description

WIS 5.0L-B1 consists of 100Ah cells which form 51.2V voltage battery module and 16 cells in serial connection (1P16S). Max parallel number is 48pcs which can expand the capacity to up to 240KWH. For meeting the needs of home storage power supply, batteries and inverters are combined to be home storage solar system with protection functions such as overcharge, over-discharge, overcurrent, overtemperature, and short circuit. For serve customers properly, the company has a big data server to facilitate after-sales maintenance, and equipped with APP display function, remote upgrade function and U-disk upgrade function. Additionally, an external integration LCD display allows customers to check the different batteries conditions and read the different batteries details more conveniently.

### 1.2 Appearance

WIS 5.0L-B1 consists of battery module (including cells and mechanical parts), battery management system (BMS) as well as power switch and communication terminals. Product appearance as below.

#### 1.2.1 Dimension (unit:mm)

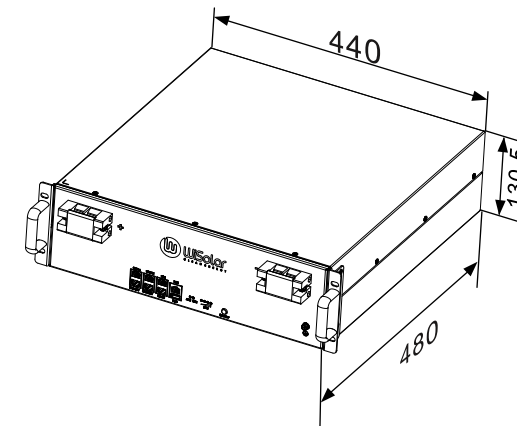

Figure 1 : Battery size diagram

## 1.2.2 Introduction to the battery operation panel

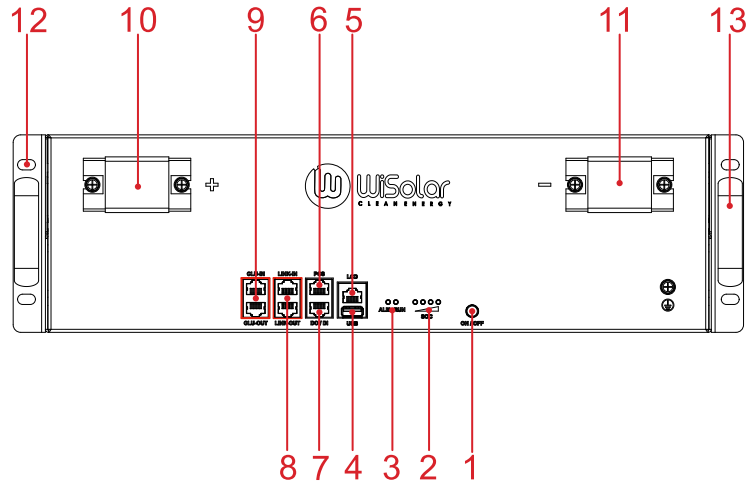

Figure 2: Introduction to the battery operation panel

Location	Port	Function
1	ON/OFF	Keys for battery on and off
2	SOC	Displaying battery SOC status
3	RUN/ALM	Displaying running status
4	USB	USB interface for system upgrade, a mobile phone can't be charged
5	LCD	For linking external integration LCD
6	PCS	Relay output/input (Output is for emergency alarm information, Input is for clustering and distinguishing)
7	DI/DO	DI/DO
8	LINK-In/LINK-Out	Link in/link out for battery parallel communication
9	CLU-In/CLU-Out	Link in/link out for clustering communication
10	+	Battery Positive
11	-	Battery Negative
12	Hanger	For fixing
13	Handle	For moving

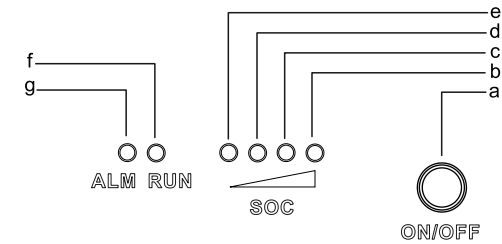

Figure3: LED light

No.	Name	Color	Description
a	ON/OFF		Power on/off Button
b	LED 4	Green	80%-100%
c	LED 3	Green	60%-79%
d	LED 2	Green	40%-59%
e	LED 1	Red/Green	0%-19%/20%-39%
f	RUN	Green	Normal Running
g	ALM	Red	Fault or protection status

## 1.3 Function and Introduction

Function	Description
APP Display and Upgrade	Display BMS information and upgrade
CAN communication	2 Circuits, with isolation, One for battery parallel communication, the other for communication with inverter
Battery in Parallel	Max parallel number is 48pcs
SOC Algorithm	Dynamic SOC estimation for battery packs
SOP Algorithm	Based on different temperature, The evaluation capacity of voltage and SOC to the maximum output or maximum input at the next moment
Running Alarm Status Display	2 LED lights to display Green: System running status, Red: Faulty status
Power off	1.Button Shutdown, 2.No Communication Shutdown, 3.Battery Low Voltage Shutdown 4.When Used in Parallel, it Can Be "One Key Shutdown"
Power on	1、Key On, 2、Charge On, 3、Activate Signal on, 4、When Used in Parallel Can "One Key On"
Balanced Management	Improve the consistency of the voltage of each single battery to protect the battery
Voltage Detection	Detect single cell voltage (14-16 strings) or total voltage (2 circuits)



Current Detection	Battery charging current, discharging current detection
Temperature Detection	Total 8 circuits. 6 circuits for battery temperature detection, 1 circuit for mosfet temperature detection, 1 circuit for battery internal ambient temperature detection
Protection	overcharge protection, over discharge protection, over-voltage protection, high temperature protection, low temperature protection, short circuit protection and hardware fault protection, etc. with record function for the fault alarm and protection, which is convenient for after-sales viewing and analysis of problems
Pre-charge Control	Charging low-voltage batteries with low current
Pre-discharge Control	Pre-charge the inverter capacitors
Interface	Same port

## 1.4 Battery software upgrade

### 1.4.1 Upgrade via USB

1. Copy the upgrade file into the U disk.
2. Turn battery off, access U disk.
3. Upgrade status indicator, RUN light flashes to enter the upgrade state, the process lasts for 3s, only RUN light is always on for 1s and then the inflow water light indicates that the upgrade is successful, only ALARM is always on for 1s and then the inflow water light indicates that the upgrade is failed (but the previous version of the program can be RUN), RUN and ALARM are always on at the same time, which means that the upgrade is failed, you need to use USB to upgrade again.
4. The battery LED light flashes in the mode of running horse light, indicating that the upgrade is completed.

Note: Choose the USB upgrade mode, there must be no other files in the U disk, otherwise the upgrade will not be possible or the upgrade error.

### 1.4.2 Upgrade via Inverter

1. Connect to WiFi monitor for remote upgrade through inverter.
2. The LED light that displays the SOC continuously flashes once per 500ms during the upgrade process.
3. The host will upgrade the slave machine in turn after the upgrade is completed.
4. During upgrading, LED lights of SOC flash once every 500ms, and become normally after the upgrade.

**Note:** Inverter remote upgrade mode can only upgrade the battery host.

## 2 Safety

Safety information contains in this section must be observed at all times when working on or with batteries. For safety, installers are responsibility to familiarize themselves with this manual and all warnings before installation.

### 2.1 Application

Please read the product manual and the warning signs on the surface of the battery box carefully before using the battery. Improper use of the battery may cause overheating and damage to the battery. The company does not assume any responsibility for any accidents caused by improper operation. In order to use and dispose of the battery safely, please read the operating instructions carefully before use:

- Keep the batteries away from heat sources, high voltage places and long periods of sunlight exposure.
- Batteries must not be thrown into water or fire.
- Do not reverse the positive and negative terminals of the battery.
- Do not use metal to short the positive and negative terminals of the battery.
- Avoid excessive physical shocks and impacts to the battery, do not hit, drop or step on the battery.
- It is strictly forbidden to disassemble or assemble the battery privately without the permission and guidance of the manufacturer.
- Cannot mix other batteries of different manufacturers, types and models.
- Do not use or store in high temperature environments, as this may cause the battery to heat up, catch fire or have a reduced service life.
- Charge the battery promptly (within 15 days) after it runs out of charge.
- Please use the matching or recommended professional lithium battery charger.
- Stop using the battery if it has abnormal conditions such as odor, discoloration, noise, liquid leakage, or serious deformation.
- If electrolyte leaks into the skin or eyes, flush with water and seek immediate medical attention.
- Please place the battery out of the reach of pets and children, and prohibit children from touching the battery.
- Below 0°C, due to the low temperature performance of the battery, please reduce the power to use, a battery pack with a load of 2.5KW or less.

### 2.2 Safety Precautions

#### 2.2.1 Environment requirements

- Do not expose the battery to temperature above 55°C ,or heat sources.
- Do not install or use the battery in wet locations, moisture , corrosive gases or liquids, such as bathroom.
- Do not expose the battery to direct sunlight for extended periods of time.
- Place battery in safe place away from children and animals.
- Battery power terminals shall not touch conductive objects such as wires.
- Do not dispose the batteries in fire, which may cause an explosion.
- The PACK shall not come in contact with liquids.
- The PACK can only be installed indoors. Regarding indoor installation, please do not install it in the bedroom, living room, kitchen, etc.

## 2.2.2 Operation and Precautions

- Do not touch the PACK with wet hands.
- Do not disassemble the PACK without permission.
- Do not crush, drop or puncture the PACK and battery.
- Dispose the batteries according to local safety regulations.
- Store and recharge battery in accordance with this manual.
- Ensure the connection of ground wire reliable.
- Remove all metal objects such as watches and rings that could cause a short-circuit before installation, replacement and maintenance.
- The Pack shall be repaired, replaced or maintained by skilled personal that has been recognized.
- When storing or handling batteries, do not stack batteries without package.
- Do not broke the battery, the released electrolyte may be toxic and is harmful to skin and eyes.
- Packaged batteries should not be stacked more than specified number stipulated on the packing case.
- Do not use damaged, failed or deformed batteries, which may lead to high temperature or even dangerous accidents. Continued operation of damaged battery may result in electrical shock, fire or even worse.



 WiSolar <small>CLEAN ENERGY</small> LiFePO <sub>4</sub> Battery	
Model Name	WIS 5.0L-B1
Nominal Voltage	51.2V
Rated Capacity	100Ah
Rated Energy	5120Wh
Max Charge Current	100A
Max Discharge Current	100A
Ingress Protection	IP20
Charge Temperature	0°C ~ 55°C
Discharge Temperature	-20°C ~ 55°C
 X Made In China	

Figure4: Nameplate

## 2.3 Warning labels

Symbols	Description
	Do not dispose in trash
	can be recycled
	Certification in European union area
	Electric shock hazard
	Explosive gas
	May leak corrosive electrolyte
	Heavy enough to cause severe injury
	Keep the Pack away from children
	Make sure the battery polarity well connected
	Do not expose to fire
	Operate according to Manual

## 2.4 Emergency Responses

Manufacturer takes foreseeable risk scenarios into consideration and is designed to reduce hazards and dangers. However, if the following situation occurs, do as below:

Situation Occurs	Treatment Solution
Leakage	1. Avoid touch of leaking liquid or gas. If you touch the leaking electrolyte, do as below immediately. 2. Inhalation: Evacuate the contaminated area, and seek medical help. 3. Eye contact: Rinse eyes with flowing water for 15 minutes, and seek medical help. 4. Skin contact: Rinse contacted area thoroughly with soap and water, and seek medical help. 5. Ingestion: Vomiting, and seek medical help.
Fire	If the battery is on fire, try to extinguish the fire with fire fighting sand and evacuate people due to the situation.
Wet Packs	If pack is flooded or submerged, do not use it. Contact Manufacturer for technical assistance immediately.
Damaged PACKS	Damaged pack are dangerous and must be handled with special attention. They are no longer suitable for use and may cause danger to people. If the pack damaged, stop use it and contact the manufacturer.

### 3 Storage and Transportation

#### 3.1 Storage Requirements

Place the battery follow the identification on the packing case during storage.

Do not put the battery upside down or sidelong.

The defective pack needs to be separated from other Batteries.

The storage environment requirements are as follows:

- 1) Install the battery in a dry and clean place with proper ventilation.
- 2) The storage temperature for a short week is between -20°C to 55°C.
- 3) If you store the pack over a long period of six months, the storage temperature is between -10°C to 40°C, relative humidity: 10%~90%RH.
- 4) Place the battery away from corrosive and organic substances (including gas exposure).
- 5) Free from direct exposure to sunlight and rain.
- 6) At least two meters away from heat sources (such as a radiator), free from exposure to intensive infrared radiation.

If the battery has not been used for more than six months, it needs to be charged, the charging procedure is as follows:

- 1) Identify the PACK that needs charging.
- 2) Refer to quick installation guidance, complete the installation and wire connection. Ensure battery in off status during all the steps.
- 3) Activating the inverter, activating the battery and starting charging.
- 4) When the RUN\_LED is always on and the SOC LED is flashing to indicate that it is in normal charging.
- 5) When the 4 SOC LED lights are always on, it indicates a full charge.

#### 3.2 Transportation Requirement

PACK has been certified in UN38.3 (Section 38.3 of the sixth Revised Edition of the Recommendations on the Transport of Dangerous Goods: Manual of Tests and Criteria) and SN/T 0370.2-2009 (Part 2: Performance Test of the Rules for the Inspection of Packaging for Exporting Dangerous Goods). PACK is classified as category 9 dangerous goods.

The PACK shall not be transported with other inflammable, explosive or toxic substances; Ensure the original Package and label complete and recognizable.

Prohibit direct exposure to sunlight, rain, condensing water caused by temperature difference and mechanical damages.

There will be a drop in capacity during transportation and storage.

Transportation temperature is between -10°C to 40°C, relative humidity: 10%~90%RH.

### 4 Installation

Ensure to read the Guidance before installation in order to understand product information and safety cautions.

Operators should be well trained technicians and fully understand the whole photovoltaic system, grid network, working principle and national regional standards.

Installers must use insulating tools and wear safety equipment.

Device damages caused by failure to comply with storage, transportation, installation and use requirements specified in Guidance are not covered by Warranty.

The PACK can only be installed indoors. Regarding indoor installation, please do not install it in the bedroom, living room, kitchen, etc.

Different types of batteries are not recommended to be mixed and used in parallel.

The battery system cannot be installed, dismantled, and maintained when it has been powered on.

#### 4.1 Installation Environment

The ambient temperature for the installation of the battery system shall be above 0°C, below 40°C, and the humidity shall between 10% -95%.

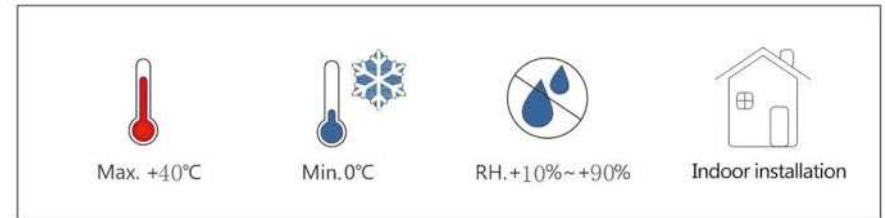



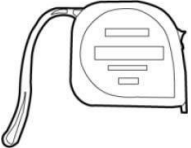



Figure 5: Installation Environment Requirements

#### 4.2 Installation Required Tools

The following tools are required to install the pack:

 <p>5mm Allen key</p>	 <p>Screw Driver</p>	 <p>Wrench</p>
 <p>Tap Measure</p>	 <p>Multi-meter</p>	

It is recommended to wear the following safety gear when dealing with the pack.



#### 4.3 Check

##### 4.3.1 Pre-installation Check

Check the package	Check the PACK package before opening it, if any abnormality is detected, do not open the package and contact your supplier.
Check the power	Check and confirm the PACK is powered off before installation.
Check deliverable	Check the quantity of all parts inside according to the package list. If there is any part missing or damaged, please contact your distributor.

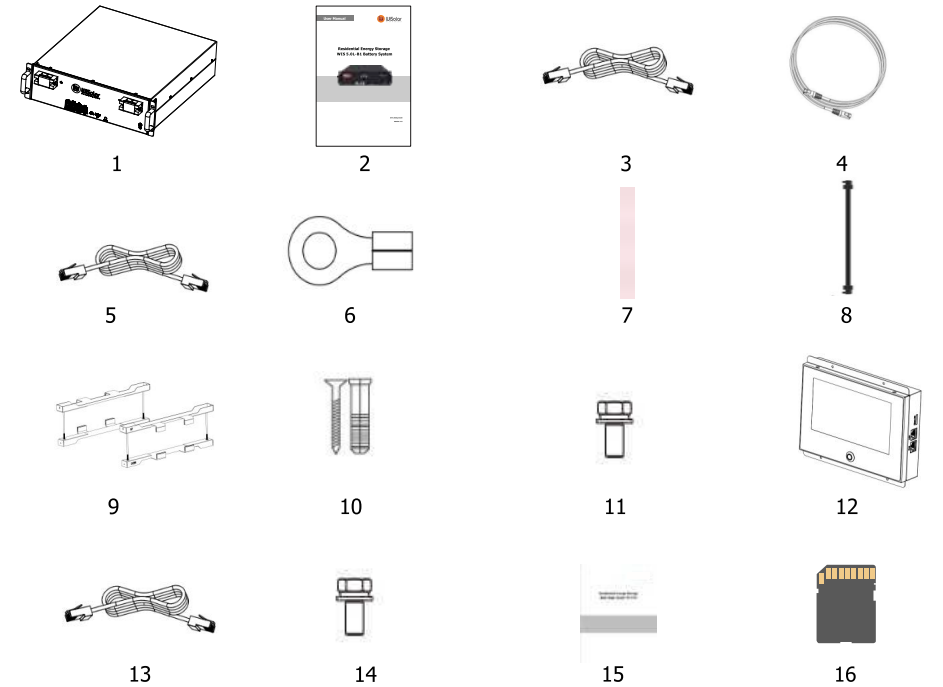

##### 4.3.2 Check Packing List

WIS 5.0L-B1 Battery Pack (Standard)			WIS 5.0L-B1 Kit package (Optional)			Batt-Intgr-Touch 7in LCD (Optional)		
Item No.	Part Name	Qty	Item No.	Part Name	Qty	Item No.	Part Name	Qty
1	WIS 5.0L-B1 Battery Pack	1 pcs	9	Battery Bracket	4 pcs	12	LCD	1 pcs
2	User Manual	1 pcs	10	Screw bolt	4 pcs	13	Network cable C	2 pcs
3	Network cable A	1 pcs	11	screw	4 pcs	14	screw	4 pcs
4	Network cable B	1 pcs				15	User manual	1 pcs
5	Network cable C	1 pcs				16	SD card	1 pcs
6	SC35-8 lug	4 pcs						
7	+ power cable	1 pcs						
8	- power cable	1 pcs						

#### 4.4 Installation

##### 4.4.1 Battery Placement

- 1) Please install indoors and ensure the level of the ground.
- 2) The maximum quantity of stacking battery pack is 6, only support to horizontally mounted. Make sure the batteries are mounted in the correct orientation. Please refer to the picture below (√ means acceptable, X means unacceptable).

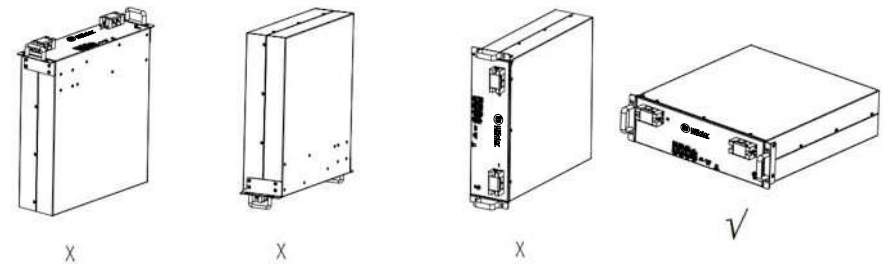

#### 4.4.2 Communication Cable Communication

Please wear an anti-static wrist strap, anti-static gloves, and goggles.

It is recommended that the power line and communication line between the battery and the inverter should not exceed 2 meters.

inverter Communication interface definition:

Item	Crystal head picture	Serial no.	Definition
PCS		1	RS485_B
		2	RS 485_A
		3	GND_COM
		4	CAN_H
		5	CAN_L
		6	GND_COM
		7	
		8	

#### 4.4.3 Single Battery Installation

Make sure the battery is in off mode and the battery breaker is off. Ensure there are no tangled cables after battery wiring.

**Step 1 :** Fix the ground wire to the ground terminal with an M4 screw, and fix the other end to the inverter. Note that the cross-sectional area of the ground wire is 16mm<sup>2</sup>.

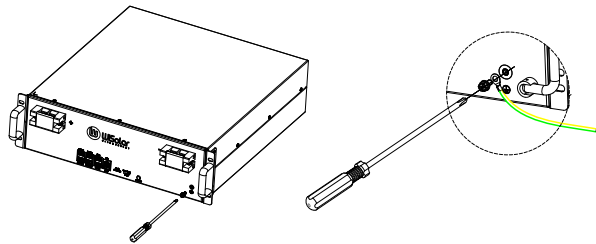

**Step 2:** Insert the network cable into the battery port.

1. Insert network cable A into the inverter port of the battery, and the other end of the network cable into the network port of the inverter.

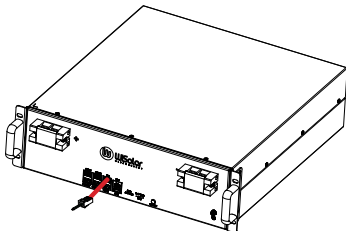

#### Step 3: Connecting Power Cable

1. Fix the OT terminal of the power cable to the pair of "+/-" terminals of the battery.
2. Put the plastic cover back.
3. Fix the other end to the breaker and then connect to the inverter.

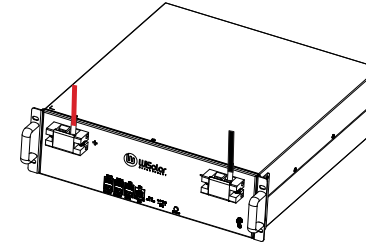

When connecting the power cable, make sure the direction of OT terminal is correct. Don't stack two OT terminals on one power port.

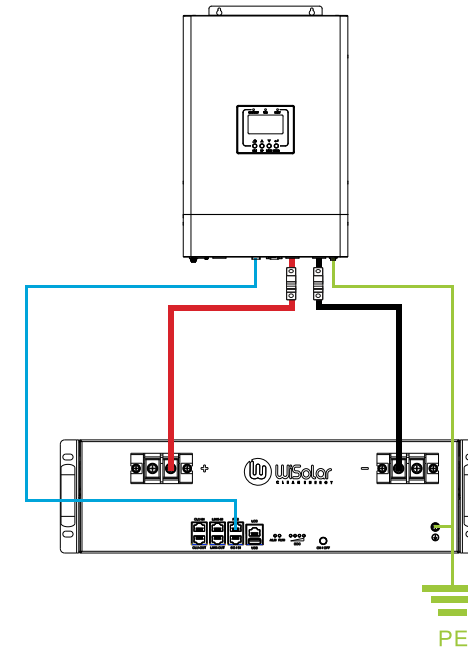

Figure 6: Single Battery Installation Diagram

- 1) The battery is not allowed to be wired in the running state, and the battery should all be off before installation.
- 2) Please install the communication line first, then protect the unused ports and USB ports against dust, and finally install the power cable.
- 3) To ensure the safety, don't forget to connect ground wire.
- 4) We recommend installing a circuit breaker between the inverter and the battery. For the specifications of the circuit breaker, we recommend using a molded case circuit breaker with a rated operating voltage greater than 80Vdc and a rated operating current greater than 200A.

#### 4.4.4 Battery Capacity Expansion Installation

- \* Ensure all batteries are in off mode, and battery breaker are off.
- \* Ensure there are no tangled cables after battery wiring.
- \* Max Capacity Expansion parallel is 10pcs to create a 7.5kw expanded energy storage system.

##### Step 1 Connect network cable

1. Insert the network cable A into the inverter port of battery 1, and the other end insert into the BMS network port of the inverter.
2. Use network cable B to connect the LINK-OUT port of battery 1 to the LINK-IN port of battery 2, Connect the rest of the batteries in the same way until the last battery is connected.

##### Step 2 Connect Ground

Connect the ground terminal of each battery to the ground strip.

##### Step 3 Connect Power Cable

Connect the +/- terminals of each battery to the +/- terminals of the next battery, and then connect the wires to the inverter.

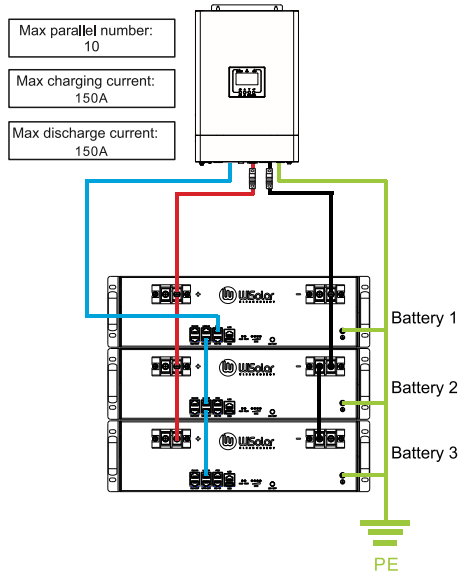

Figure 7: Capacity Expansion Installation Diagram

- 1) The battery is not allowed to be wired in the running state, and the battery should all be off before installation.
- 2) Refer to Figure 7 for power cable wiring.
- 3) Please install the communication line first, then protect the unused ports and USB ports against dust, and finally install the power cable.
- 4) We recommend installing a circuit breaker between the inverter and the battery. For the specifications of the circuit breaker, we recommend using a molded case circuit breaker with a rated operating voltage greater than 80Vdc and a rated operating current greater than 200A.

**Note:** The number of batteries in parallel is at least three, and the maximum working current can reach 150A, otherwise the maximum working current is only 100A.

#### 4.4.5 Battery Pack Power Expansion Installation

- \* Make sure all batteries are in off mode and the battery circuit breaker is off.
- \* Make sure there are no tangled cables after the battery wiring.
- \* Max Output Power Expansion parallel is 10pcs to create a 50kw expanded energy storage system.

##### Step 1: Connect Network Cable

1. Insert one end of the network cable A into the inverter interface of battery 1 and the other end into the BMS network port of the inverter.
2. Connect the LINK-OUT connector of battery 1 and the LINK-IN connector of battery 2 using network cable B. Connect the rest of the batteries in the same way until the last battery is connected.

##### Step 2: Connect the Ground Wire

Connect the ground terminal of each battery to the grounding strip.

##### Step 3: Connect Power Cable

Connect the +/- terminal of each battery into the +/- terminal of the latter battery separately, and then connect the wires to the inverter.

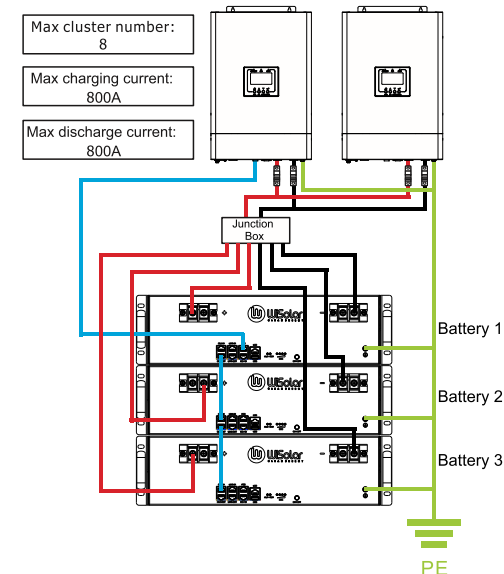

Figure 8: Installation Diagram for Power Expansion

- 1) The battery is not allowed to be wired in the running state, and make sure all batteries are in off mode before installation.
- 2) Refer to Figure 8 for power cable wiring.
- 3) Please install the communication line first, then protect the unused ports and USB ports against dust, and finally install the power cable.
- 4) We recommend installing a circuit breaker between the inverter and the battery. For the specifications of the circuit breaker, we recommend using a molded case circuit breaker with a rated operating voltage higher than 80Vdc, the rated working current is determined by the power. It is recommended to connect a battery pack to a 125A circuit breaker, and connect multiple battery packs to 125A\*n circuit breaker.



#### 4.4.6 Battery Pack Capacity and Power Expansion Installation

- \* Ensure all batteries are in off mode and battery breakers are off.
- \* Ensure there are no tangled cables after battery wiring.
- \* Support up to 48 battery packs connected in parallel to form a 60KW expanded energy storage system.

##### Step 1: Connect The Network Cable

1. Insert one end of the network cable A into the inverter interface of battery 1 and the other end into the BMS network port of the inverter.
2. Connect the LINK-OUT connector of battery 1 and the LINK-IN connector of battery 2 using network cable B. Connect the rest of the batteries in the same way until the last battery is connected.
3. Connect CLU-OUT port of master battery in main cluster and CLU-IN port of master battery in Slave Cluster, connect rest of batteries in the same way until the last battery is connected.

##### Step 2 Connect The Ground Wire

Connect the ground terminal of each battery to the grounding strip.

##### Step3 Connect The Power Cord

Connect the +/- terminal of each battery into the +/- terminal of the Junction box separately, and then connect the wires to the inverter.

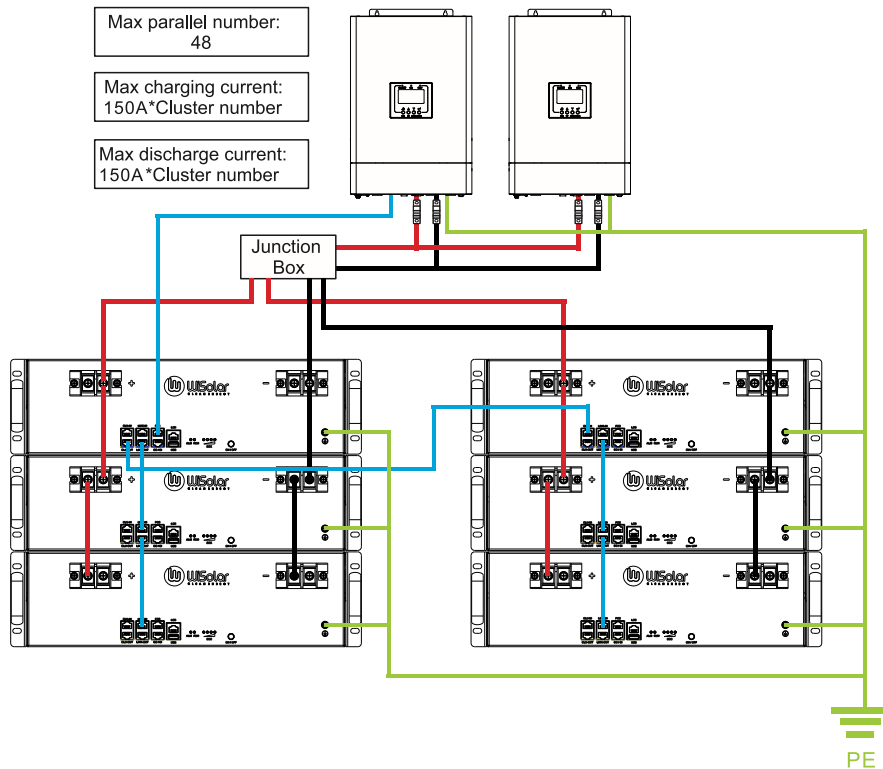

Figure 9: Installation Diagram for Capacity Expansion

- 1) The battery is not allowed to be wired in the running state, and the battery should all be off before installation.
- 2) Refer to Figure 9 for power cable wiring.
- 3) Please install the communication line first, then protect the unused ports and USB ports against dust, and finally install the power cable.
- 4) We recommend installing a circuit breaker between the inverter and the battery. For the specifications of the circuit breaker, we recommend using a molded case circuit breaker with a rated operating voltage higher than 80Vdc, the rated working current is determined by the power. It is recommended to connect a battery pack to a 125A circuit breaker, and connect multiple battery packs to 125A\*n circuit breaker.

#### 4.4.7 Stackable Installation with Bracket Support

Check and confirm the battery is powered off and battery breakers are turned off before any process.

Step1: prepare support brackets

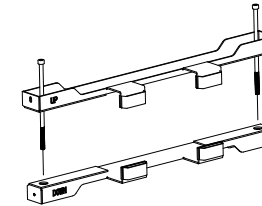

Step2: set battery into 2pcs of brackets from the rear.

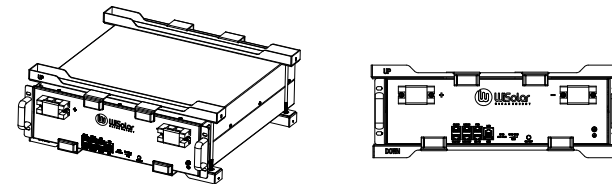

Step3: stack battery packs with brackets and fasten screws.

Max 6 pcs battery packs can be stacked in this way.

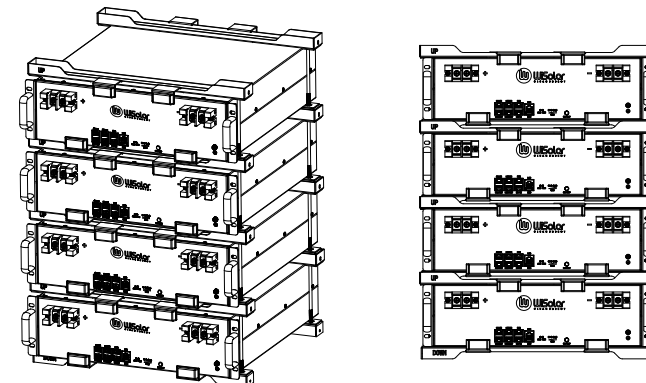

## 5 Power on/off

The installation and use of batteries involve much specialized knowledge. Therefore, technicians should be given appropriate technical training and obtain operational certificates in compliance with local laws and regulations. Please ensure technicians have obtained training certificate before operation.

Please stand on dry insulating objects and do not wear conductive material such as watches and necklace during operation. Insulated tools should be used.

Do not contact any positions with voltage potential difference.

Prohibition sign should be hung on the battery: " Non-professionals, do not touch" .

If any abnormalities occur during the startup phase, power off the pack immediately. After problem confirmed, proceed again.

Make sure the inverter is turned off before checking the pack.

### 5.1 Power on

When multiple batteries are connected in parallel or multiple clusters of batteries are connected in parallel, press one of the battery power buttons and all the batteries connected in parallel can be turned on.

Power on the PACK by pressing power button(t>1S)		
Item	procedures	Acceptation criteria
1	Connect battery and inverter	Make sure the wiring harnesses are well connected.
2	Turn on breaker of battery	Make sure breaker of battery is ON.
3	Press power switch for 1 second,and observe LED indication on panel	1. if indication of RUN/ALM and SOC is ON, pack is powered on successfully. 2. if ALM indication turn red, pack have fault, and should solve it before turning it on again.
Power on pack by inverter		
1	Connect inverter and battery	Make sure the wiring harnesses are well connected.
2	Turn on breaker of battery	Make sure breaker of battery is ON
3	Power on inverter for charging battery	1. if indication of RUN/ALM and SOC is ON, pack is powered on successfully. 2. if ALM indication turn red, pack have fault, and should solve it before turning it on again.

### 5.2 Power off

Press the power switch for 3 seconds and release it, battery off, all LED lights off. If multiple batteries are connected in parallel, only press the power switch of any one of the batteries for 3 seconds and then release it, the other batteries can be turned off.

## 6 Maintenance Guide

### 6.1 Preparation

Tools like safety gloves, cross head driver and socket wrench should be prepared.

Turn off and turn on new PACK

1. If the PACK is power-off. Press power button for 1 second to turn on.

2. If the PACK is power-on. Press power button 3-5 seconds to turn off.

Before maintaining the battery, turn off the breaker and press power button 3-5 seconds to make sure the battery is power-off. Follow the installation and wire connection procedures specified above. Ensure wires are properly connected before turn the breaker on. After that, turn on the breaker and press power button of any battery for 1 second to check if the system normal works

### 6.2 Battery Replacement

Wear safety gloves.

Open the breaker and power off the battery.

Remove your safety screw under the power supply, and disconnect the power cord and CAN. communication line of the battery.

Remove the safety part at the left end of the battery and lift the battery upward.

Put the battery into the packing box according to the repair procedure and transport the battery to the designated repair site.

Install new battery based on procedure specified in Section 4.

### 6.3 System Failure Information List and Trouble Shooting Suggestions

Error Indication	Error Description	Error Cause	Suggested Actions
* (ALM light flickers)	Discharge under voltage protection	Cell voltage/battery voltage below the threshold of under voltage protection	there is no safety risk, but user should stop discharging and arrange charging,
	Charge over voltage protection	cell voltage/battery voltage above the threshold of over voltage protection	There is safety risk.user should stop charging,and make it in idle or discharging until recoving to normal status.



* ( ALM light flickers )	External communication failure	Failed communication for battery and inverter	<ol style="list-style-type: none"> <li>1.there is no safety risk, but user should stop using.</li> <li>2. Check whether communication between inverter and battery is normal.</li> <li>3. if battery and inverter communication failed, but ensure communication wire connection well,please contact installer for repairing battery.</li> </ol>
	Internal communication failure	Communication loss of two battery packs in parallel	Check CAN connection of link-in and link-out between two battery PACKS.
	Parallel failure	There is alarm in parallel mode	<ol style="list-style-type: none"> <li>1.Check CAN connection of batteries.</li> <li>2.Check wire connection of batteries.</li> </ol>
● (ALM light on)	Dicharge short circuit	External short circuit of battery	<ol style="list-style-type: none"> <li>1.Safety risk exist,please stop using it.</li> <li>2.User need contact installer for repairing</li> </ol>
	Pre-charge short circuit		
	Pre-charge timeout		
	Parallel failure	Different firmware version	<ol style="list-style-type: none"> <li>1.Safety risk exist,please stop using it.</li> <li>2.User need contact installer for updating the same firmware version.</li> </ol>
	Main circuit fault	BMS main power circuit fault	<ol style="list-style-type: none"> <li>1.Safety risk exist,please stop using it.</li> <li>2.User need contact installer for repairing.</li> </ol>
MOS control fault	After turn off mosfet, there is still current.	<ol style="list-style-type: none"> <li>1.Safety risk exist,please stop using it.</li> <li>2.User need contact installer for repairing.</li> </ol>	

## 7 Technical Specifications

Functional parameters of WIS 5.0L-B1 are as below:

No.	Items	Specification
1	Battery Module	WIS 5.0L-B1
2	Rated Capacity/Energy	100Ah/5.12kWh
3	Nominal Voltage	51.2V
4	Operating voltage	40-58.4
5	Max.charging current(25°C)	100A
6	Max.discharging current(25°C)	100A
7	Max peak current	250A 150ms
8	Battery Type	Lifepo4
9	Operative Charging Temperature Range	0°C~55°C
10	Operative Discharging Temperature Range	-20°C ~55°C
11	Storage Conditions	-20°C~45°C、20%-40%SOC、Relative Humidity≤60% Recommended temperature: 0°C - 35°C Within six months after initial charge
12	Cooling	Natural Cooling
13	Dimension(W / D / H)	( 440 ) / ( 480 ) / ( 130.5 ) mm
14	Weight	43±2kg
15	Installation Type	Rack Mount
16	Ingress Protection	IP 20
17	Safety Certificate	CE(EMC)/UN38.3/MSDS/ROHS/IEC 62619
18	Communication port	CAN/RS485
19	Max.Parallel number	48 pcs

## Appendix 1

Status	Items	SOC indicator			
		LED1	LED2	LED3	LED4
Charge SOC	0%	● (t=500ms)	● (t=500ms)	● (t=500ms)	● (t=500ms)
	1%-19%	● (t=500ms)	● (t=500ms)	● (t=500ms)	● (t=500ms)
	20%-39%	●	● (t=500ms)	● (t=500ms)	● (t=500ms)
	40%-59%	●	●	● (t=500ms)	● (t=500ms)
	60%-79%	●	●	●	● (t=500ms)
	80%-100%	●	●	●	●
Discharge SOC	100%-80%	●	●	●	●
	79%-60%	●	●	●	
	59%-40%	●	●		
	39%-20%	●			
	19%-1%	●			
	0%	● (t=500ms)			
Idle	100%-80%	●	●	●	●
	79%-60%	●	●	●	
	59%-40%	●	●		
	39%-20%	●			
	19%-1%	●			
	0%	● (t=500ms)			

When in charging stage & SOC in range of 0% ~ 79%, LED indicators flash one by one which means in charging stage.

When battery SOC at 100%, LED indicators solid on means in fully charged stage.

When In discharging and idle stage, LED indicators do not flash, but are lighted on according to its real-time SOC %. Only when red/green led indicators flash which means battery low power, and says "charging please".

When SOC at 0%, only red LED indicator flashes, others led indicators are off.

LED indicator 2			
Status	Item	RUN	ALM
Charge & discharge MOS	Open circuit	● ( t=1s)	
	Closed circuit	●	
Alarm	Battery under voltage		● (t=1s)
	Battery over voltage		● (t=1s)
	Cell under voltage		● (t=1s)
	Cell over voltage		● (t=1s)
	Alarm before shut off		● (t=1s)
	Charge over current		● (t=1s)
	Discharge over current grade1		● (t=1s)
	Internal CAN communication failure		● (t=1s)
	Large internal & external voltage difference		● (t=1s)
	Charge low temperature		● (t=1s)
	Discharge low temperature		● (t=1s)
	Charge high temperature		● (t=1s)
	Discharge high temperature		● (t=1s)
	Charge over power		● (t=1s)
	Discharge over power		● (t=1s)
	Large charging circulation		● (t=1s)
	Large discharging circulation		● (t=1s)
	Mos high temperature		● (t=1s)
	Big Cell voltage difference		● (t=1s)
	Big Cell temperature difference		● (t=1s)
High ambient temperature		● (t=1s)	
Communication between clusters failed		● (t=1s)	
MCU short circuit		● (t=1s)	

	FET short circuit		● (t=1s)
	Too many parallel machines		● (t=1s)
Protection	Battery under voltage		●
	Battery over voltage		●
	Cell under voltage		●
	Cell over voltage		●
	Short circuit		●
	Charge over current		●
	Discharge Over current 1 grade		●
	Parallel versions are inconsistent		●
	Parallel failure		●
	Big voltage difference for internal and external		●
	MOS control failure		●
	Low charge temperature		●
	Low discharge temperature		●
	High charge Temperature		●
	High Discharge Temperature		●
	Charge over power		●
	Discharge over power		●
	Same Address Failure		●
	Pre-charge Timeout		●
	Pre-charge short circuit		●
	AFE disconnected		●
	Cell sampling cable disconnected		●
	Temperature sampling cable disconnected		●
Abnormal Battery Voltage Sampling		●	

	Temperature Short Circuit		●
	Abnormal Load Voltage Sampling		●
	Failed to load parameters		●
	AFE over voltage		●
	AFE under voltage		●
	AFE charging over current		●
	AFE discharging over current		●
	Excessive differential voltage between primary and secondary		●
	charge current limit failure		●
	Discharge current limit failure		●
	Main circuit disconnection		●
	Discharge overcurrent grade 2		●
	MOS high temperature alarm		●
	Excessive differential voltage		●
	Excessive differential temperature		●
	High ambient temperature		●
	Inconsistent versions between clusters		●
	Duplicate failures between clusters		●
	FET Over charge temperature		●
	FET Low charge temperature		●
	FET Over discharge temperature		●
	FET Low discharge temperature		●

**Note:** ● Indicates always on  
● t=500ms indicates the flashing interval 500ms ● t=1s indicates the flashing interval 1s

Appendix 2

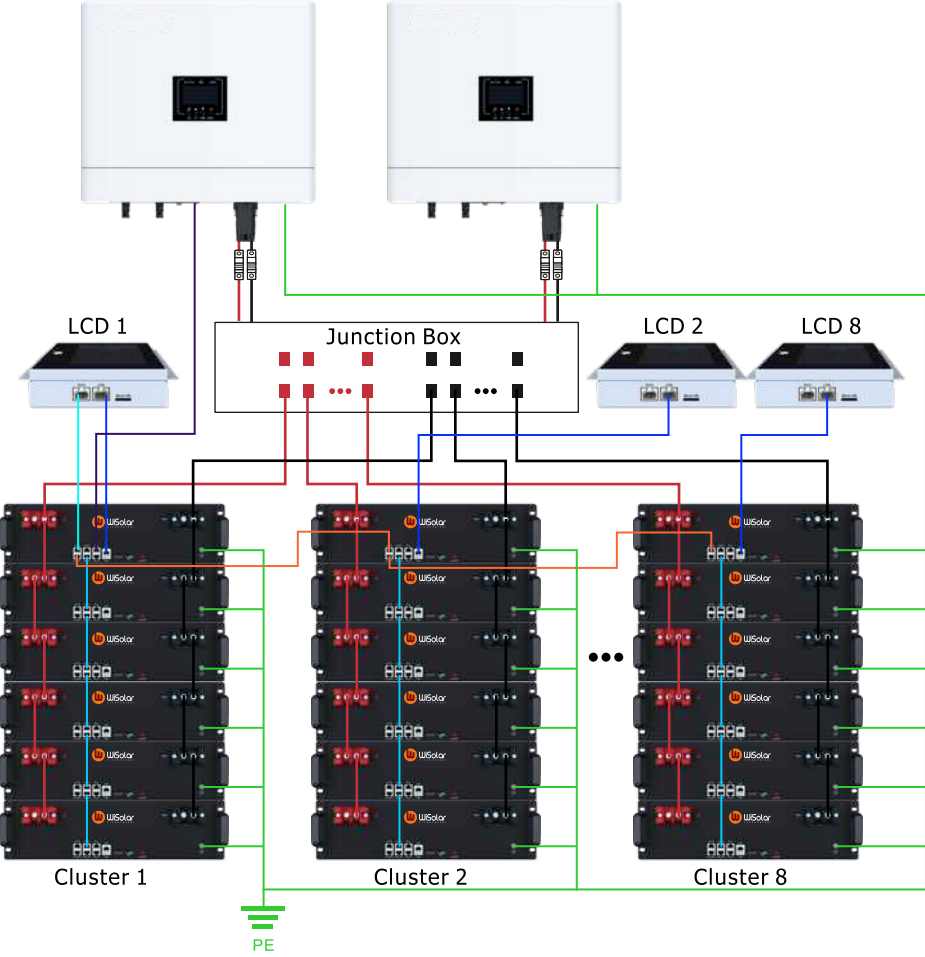

Wiring diagram